Bluetooth Module Datasheet

Model: SJR-BTM835

Version: V1.4

2016-01-29

Sky Jiarun Technologies Co., Ltd.

Tel: (0755)85279490

E-mail: sales@tianjiarun.com

Web: www.tianjiarun.com

Baoan, Shenzhen

List of Contents

1 Introduction	3
2 Key Features	3
3 Applications	4
4 Block Diagram	4
5 General specifications	4
6 Module Package Information	5
6.1 Pinout Diagram and package dimensions	5
6.2 Module Pin descriptions	6
7 Electrical Characteristics	8
7.1 Absolute Maximum Ratings	8
7.2 Recommended Operating Conditions	8
8 Recommended reflow temperature profile	9

1 Introduction

Sky Jiarun Technologies introduces the pioneer of the Bluetooth 4.1 modules SJR-BTM835 which is a high performance, cost effective, low power and compact solution. The Bluetooth module provides a complete 2.4GHz Bluetooth system based on the BlueCore CSR8635 chipset which is a single chip radio and baseband IC for Bluetooth 2.4GHz systems,. This module is fully compliant to Bluetooth v4.1 for audio communications.

2 Key Features

Bluetooth Profiles

- Bluetooth v4.1 specification support
- A2DP v1.2
- AVRCP v1.4
- HFP v1.6
- HSP v1.2
- DI v1.3

Music Enhancements

- Configurable 5-band EQ for music playback (rock,pop, classical, jazz, dance etc)
- SBC, MP3, AAC and Faststream decoder
- Volume Boost
- Stereo Widening (S3D)

Additional Functionality

- Support for multi-language programmable audio prompts
- CSR's proximity pairing and CSR's proximity connection
- Multipoint support for A2DP connection to 2 A2DP sources for music playback
- Talk-time extension
- Slim module with 28.5mm x 13mm x 2.5mm

3 Applications

- Stereo Headsets
- Wired Stereo headsets and headphones
- Portable Bluetooth Stereo speakers

4 Block Diagram

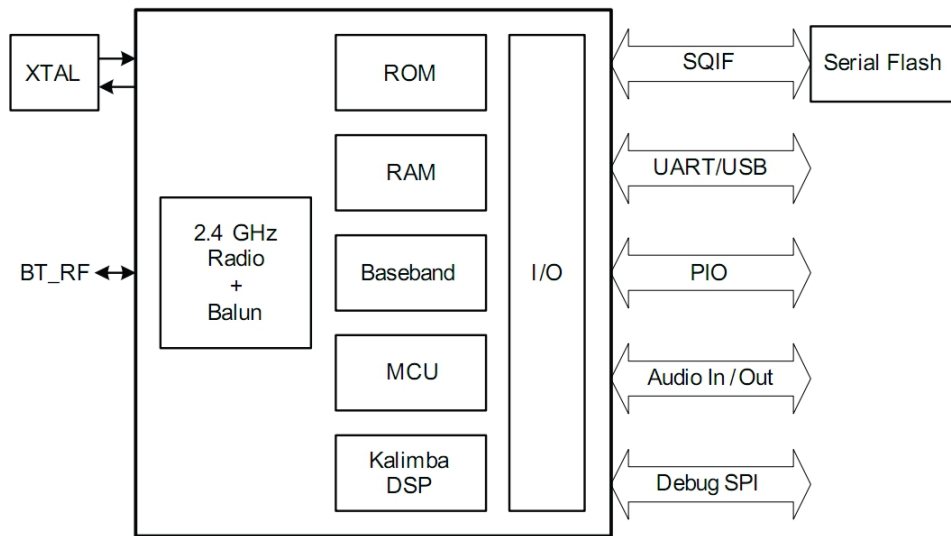

5 General specifications

Model Name	SJR-BTM835
Product Description	Bluetooth 4.1 Class2 Module
Bluetooth Standard	Bluetooth 4.1
Chipset	CSR8635
Dimension	28.5mm x 13mm x 2.5mm
Operating Conditions	
Voltage	2.8~4.2V
Temperature	-10~+70°C
Storage Temperature	-40~+85°C
Electrical Specifications	
Frequency Range	2402~2480MHz
Maximum RF Transmit Power	4dBm
$\pi/4$ DQPSK Receive Sensitivity	-91dBm
8DPSK Receive Sensitivity	-81dBm

6 Module Package Information

6.1 Pinout Diagram and package dimensions

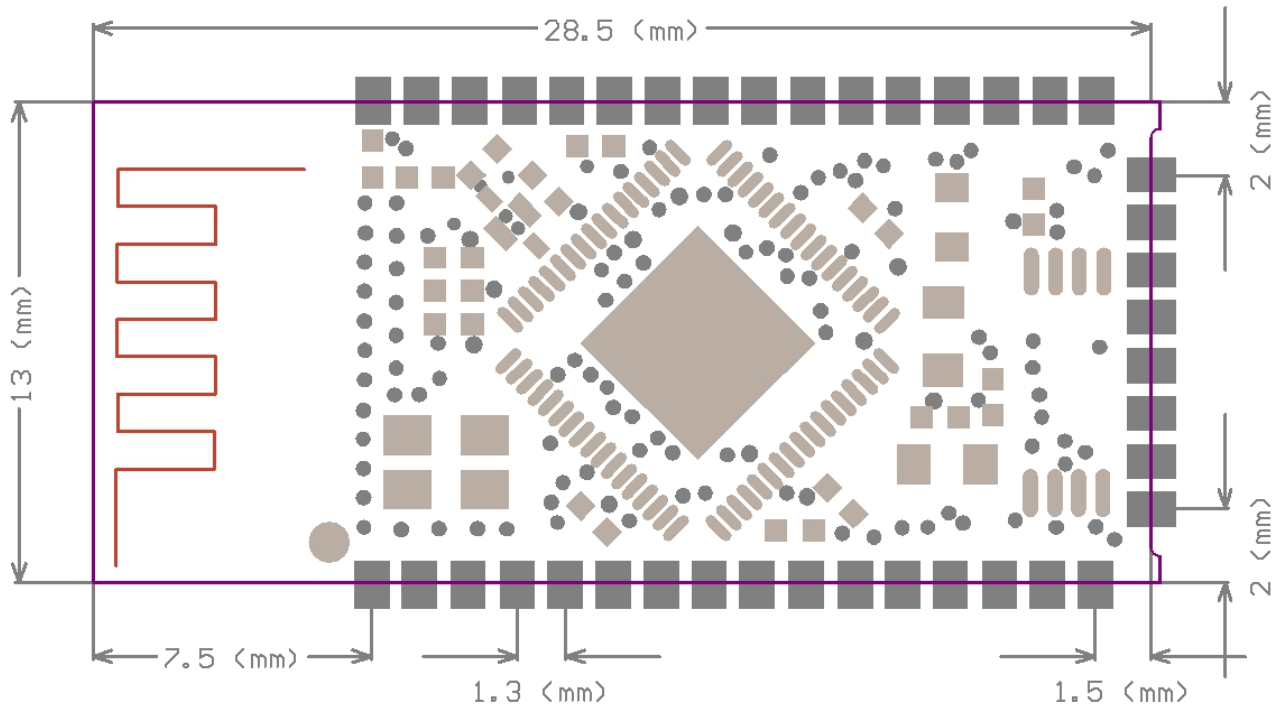

Unit: MM

Recommended PCB layout footprint

6.2 Module Pin descriptions

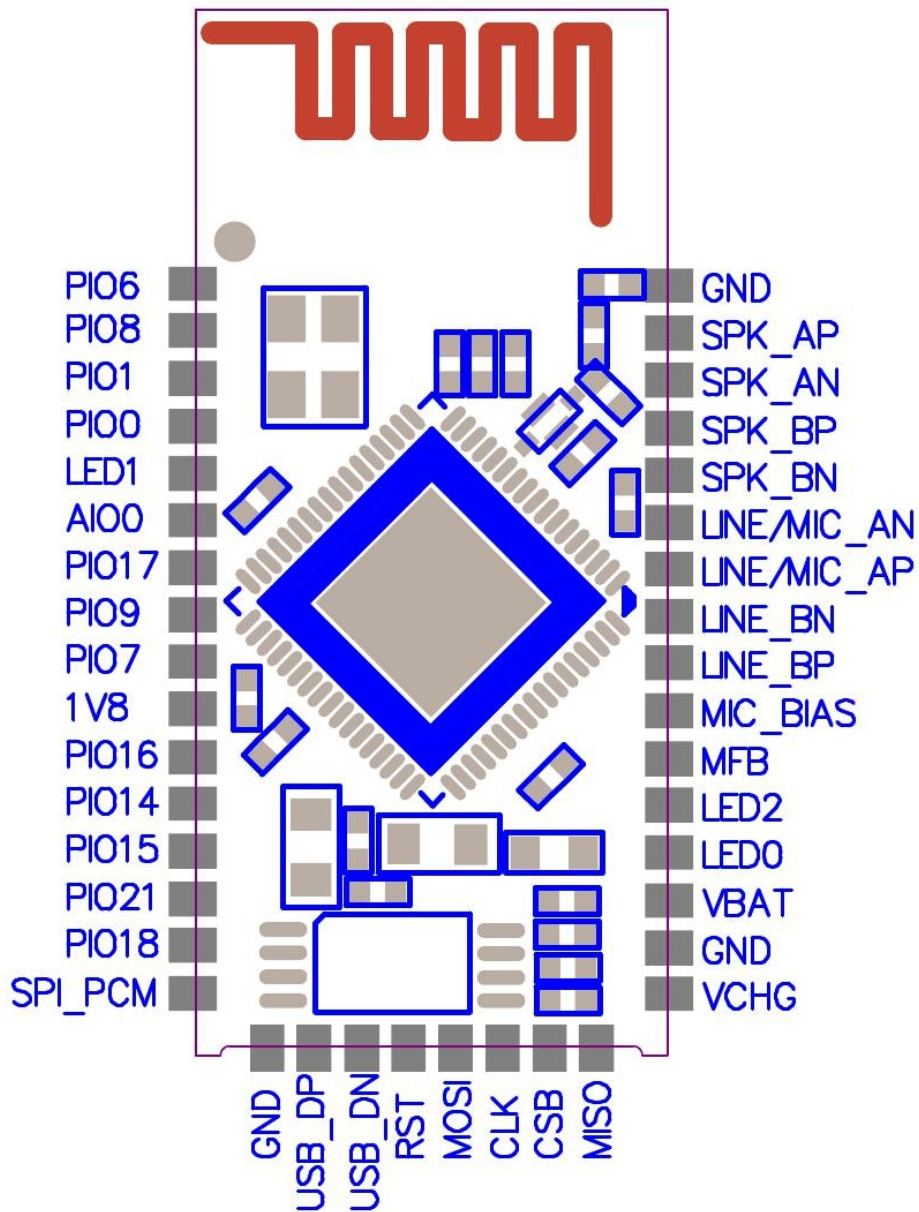

Pin No.	Pin Name	Pin Type	Description
1	PIO6	Bidirectional with strong pull-down	Programmable input/output line 6
2	PIO8	Bidirectional with strong pull-up	Programmable input/output line 8
3	PIO1	Bidirectional with strong pull-up	Programmable input/output line 1
4	PIO0	Bidirectional with strong pull-up	Programmable input/output line 0
5	LED1	Bidirectional	LED driver
6	AIO0	Bidirectional	Analogue programmable input/output line
7	PIO17	Bidirectional with strong pull-down	Programmable input/output line 17
8	PIO9	Bidirectional with strong pull-down	Programmable input/output line 9

9	PIO7	Bidirectional with strong pull-down	Programmable input/output line 7
10	1V8	1.8V output	1.8V output for keys
11	PIO16	Bidirectional with strong pull-up	Programmable input/output line 16
12	PIO14	Bidirectional with strong pull-up	Programmable input/output line 14
13	PIO15	Bidirectional with strong pull-up	Programmable input/output line 15
14	PIO21	Bidirectional with weak pull-down	Programmable input/output line 21
15	PIO18	Bidirectional with weak pull-down	Programmable input/output line 18
16	SPI_PCM#	Input with weak pull-down	SPI/PCM select input: 0 = PCM/PIO interface 1 = SPI
17	GND	VSS	Ground
18	USB_P	Bidirectional	USB data plus
19	USB_N	Bidirectional	USB data minus
20	RSTn	Input with strong pull-up	Reset if low. Pull low for minimum 5ms to cause a reset.
21	SPI_MOSI	Bidirectional with weak pull-down	Programmable input / output line 2 Alternative function: SPI_MOSI: Debug SPI data input
22	SPI_CLK	Bidirectional with weak pull-down	Programmable input / output line 5 Alternative function: SPI_CLK: Debug SPI clock
23	SPI_CSB	Bidirectional with weak pull-down	Programmable input / output line 4 Alternative function: SPI_CS#: chip select for Debug
24	SPI_MISO	Bidirectional with weak pull-down	Programmable input / output line 3 Alternative function: SPI_MISO: Debug SPI data output
25	VCHG	Charger voltage input	Internal charger input for charging
26	GND	VSS	Ground
27	VBAT	Battery positive terminal	Power supply input for 2.8~4.2V
28	LED0	Bidirectional	LED driver
29	LED2	Bidirectional	LED driver
30	VREG_EN	Power on/off key input	Power on/off input key indication

31	MIC_BIAS	Analog	Microphone bias output
32	LINE_BN	Analog input	Line input negative, channel B
33	LINE_BP	Analog input	Line input positive, channel B
34	LINE/MIC_AP	Analog input	Line or microphone input positive, channel
35	LINE/MIC_AN	Analog input	Line or microphone input negative, channe
36	SPK_BN	Analog output	Speaker output negative right
37	SPK_BP	Analog output	Speaker output positive right
38	SPK_AN	Analog output	Speaker output negative left
39	SPK_AP	Analog output	Speaker output positive left
40	GND	VSS	Ground

7 Electrical Characteristics

7.1 Absolute Maximum Ratings

Rating	Minimum	Maximum
Storage temperature	-40°C	+85°C

7.2 Recommended Operating Conditions

Operating Condition	Minimum	Maximum
Operating temperature range	-10°C	+70°C
Supply voltage: VBAT	+2.8V	+4.2V

8 Recommended reflow temperature profile

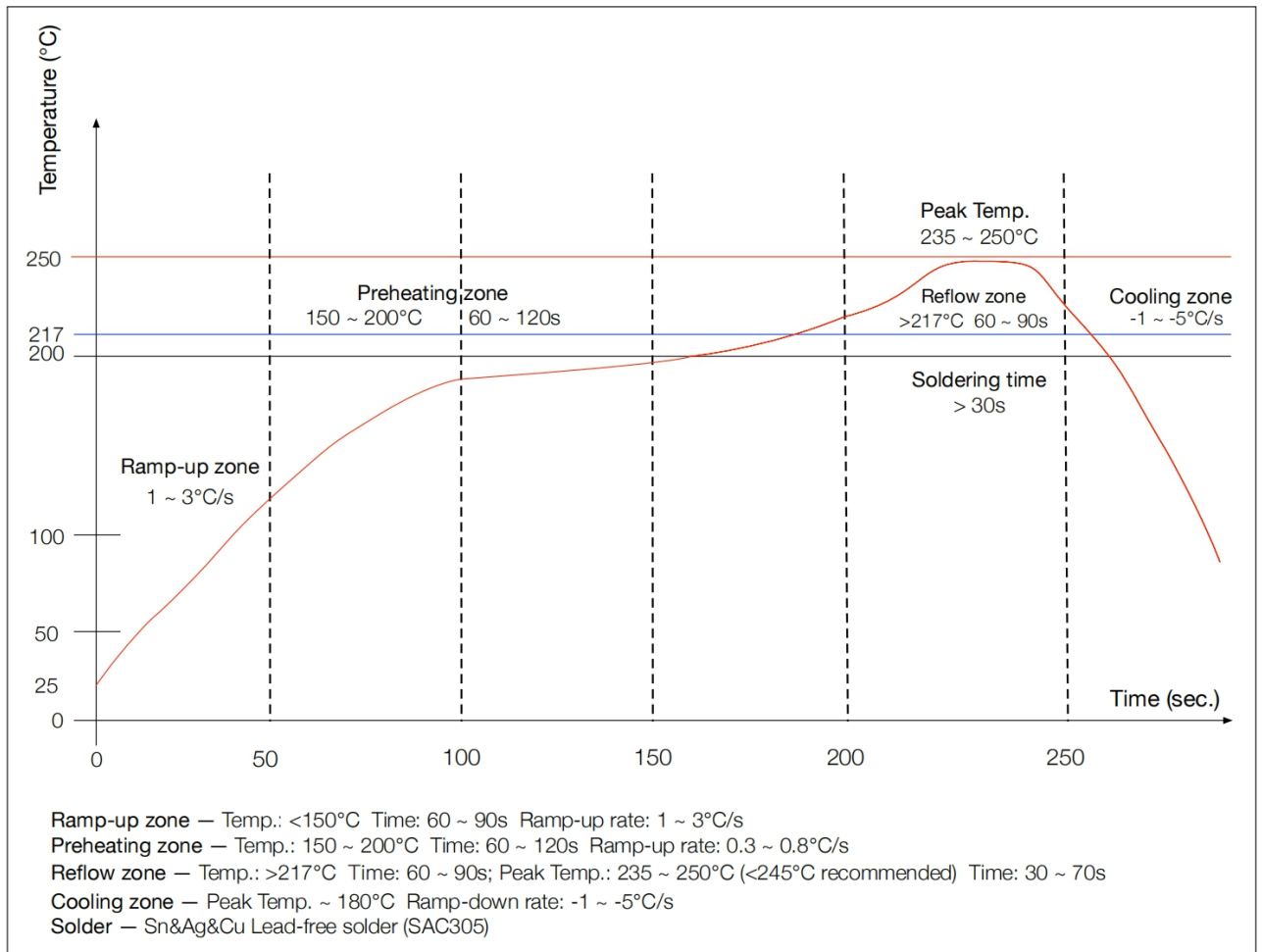

The module Must go through 125°C baking for at least 9 hours before SMT AND IR reflow process!

若拆封后未立即上线，天嘉润科技建议让下次上线前务必以 **125°C** 烘烤 **9** 小时以上！

Record of Changes

Data	Revision	Description
2013-11-26	V1.0	Original publication of this document.
2016-01-29	V1.4	

IMPORTANT NOTICE

Sky Jiarun Technologies Co.,Ltd (SJR) reserve the right to make changes to their products or to discontinue any product or service without notice, and advise customers to obtain the latest version of relevant information to verify, before placing orders, that information being relied on is current. All products are sold subject to the SJR terms and conditions of sale supplied at the time of order acknowledgement, including those pertaining to warranty, patent infringement, and limitation of liability.

SJR warrants performance of its products to specifications applicable at the time of sale in accordance with SJR's standard warranty. Testing and other quality control techniques are utilized to the extent SJR deems necessary to support this warranty. Specific testing of all parameters of each device is not necessarily performed, except those mandated by government requirements.

In order to minimize risks associated with customer applications, adequate design and operating safeguards must be used by the customer to minimize inherent or procedural hazards. SJR products are not authorized for use as critical components in life support devices or systems without the express written approval of an officer of the company. Life support devices or systems are devices or systems that are intended for surgical implant into the body, or support or sustain life, and whose failure to perform when properly used in accordance with instructions for use provided, can be reasonably expected to result in a significant injury to the user. A critical component is any component of a life support device or system whose failure to perform can be reasonably expected to cause the failure of the life support device or system, or to affect its safety or effectiveness.

SJR assumes no liability for applications assistance or customer product design. SJR does not warrant or represent that any license, either express or implied, is granted under any patent right, mask work right, or other intellectual property right of SJR covering or relating or any combination, machine, or process in which such products or services might be or are used.

Tel: (0755) 85279490

Fax :(0755) 85279683

Web: www.tianjiarun.com

E-mail: sales@tianjiarun.com